

# AMERICAN STANDARD

## HERON SQUARE VESSEL BASIN

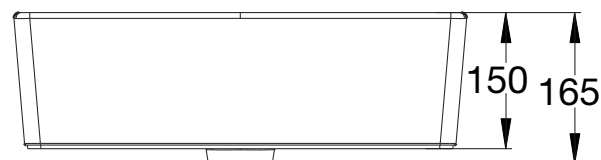
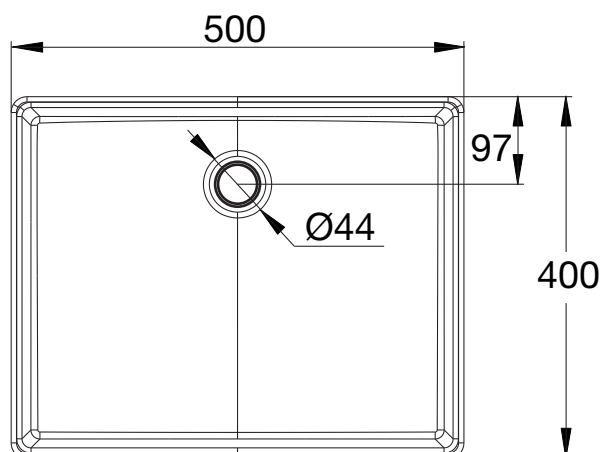

Dimensions are nominal measurements only.

### SPECIFICATION

<b>Recommended Use</b>	Domestic, hotel or commercial
<b>Material</b>	Fine Fire Clay
<b>Weight</b>	11.5kg
<b>Fixing Requirements</b>	Sealed to countertop with waterproof sealant
<b>Integrated Overflow</b>	No
<b>Tap Hole Availability</b>	None
<b>Plug &amp; Waste</b>	Suits 32 x 40mm, No overflow waste
<b>Capacity</b>	21 litres
<b>Colour Availability</b>	White
<b>Template</b>	Supplied



### CLEANING RECOMMENDATIONS

We recommend the use of soapy water or approved cleaners. This product should not be cleaned with abrasive materials. Damage caused by any improper treatment is not covered by the product warranty. Refer to Warranty Conditions.

Disclaimer: Products in this specification manual must by regulation be installed by licensed and registered trade people. The manufacturer/distributor reserves the right to vary specifications or delete models from their range without prior notification. Dimensions are nominal measurements only. Dimensions and setouts listed are correct at time of publication however the manufacturer/distributor takes no responsibility for printing errors.

Tech Page Version 1

*American  
Standard*

# AMERICAN STANDARD HERON SQUARE COUNTER BASIN

## INSTALLATION

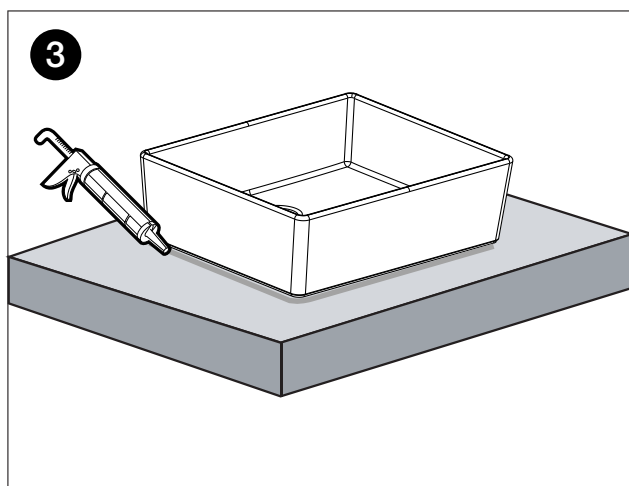
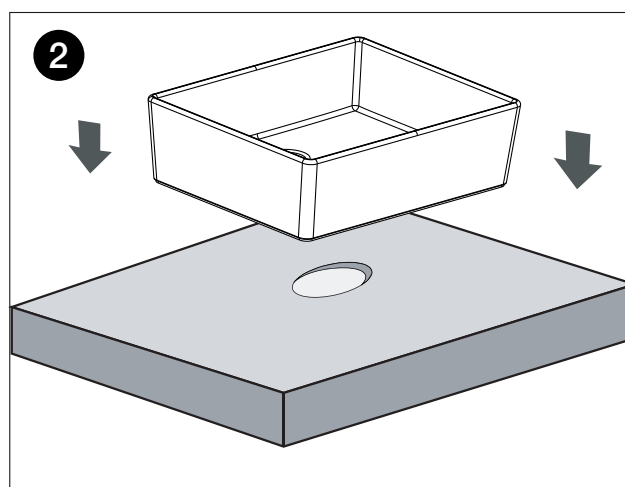
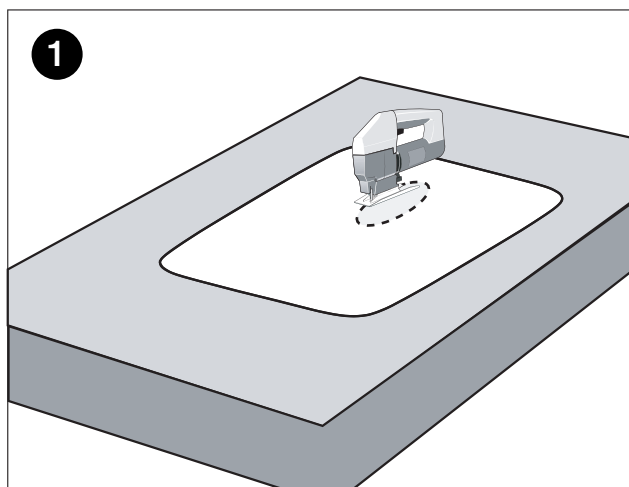
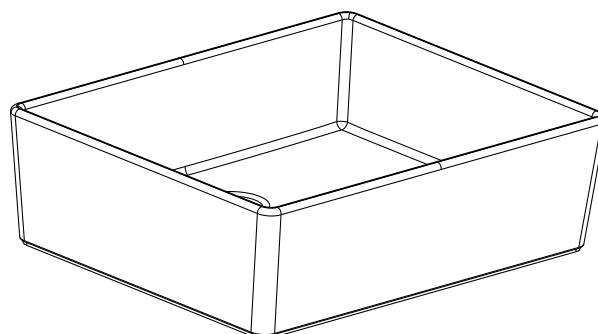

Plumbers, please ensure a copy of the installation instructions is left with the end user for future reference